

RAVEEVI

D V L E D

RAVE

D V L E D

Light, stable & durable, best for super huge lightweight stage

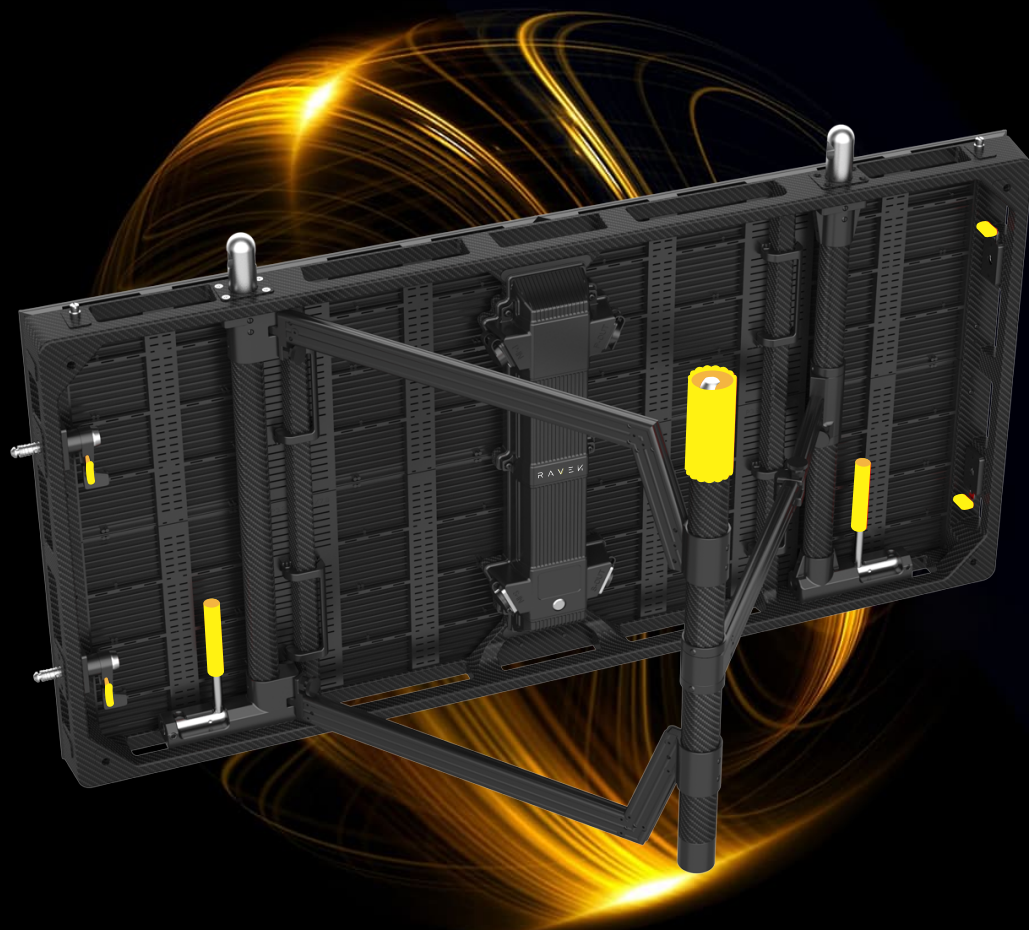

Light, thin & durable



Fully modularized design

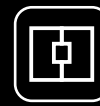

Seamless stitching with high precision

Outdoor: H5.9mm*9mm
Outdoor mesh: H5.9.9mm*V5.9mm | H3.9MM*V7.8MM
Indoor: H3.9mmV3.9mm

FEEA
TU
RES

Features

- Ergonomic carbon fiber cabinet design which is super light&thin with high strength, strong toughness and great heat dissipation, also easy to handle by one person
- Fully magnetic & large led module 500*250mm + clip type module handle allow for front & rear maintenance easy, and make installation efficient and reliable
- Hollow design allowed which makes its windproff ability strong and enriches the stage's creative possibilities, wind resistance up to 25m/s
- Modularized design with integrated detachable control box, fast and easy to maintain
- Both for indoor & outdoor usage with high IP rate (Ip65), and anticorrosion by carbon fiber material
- Instant and seamless stitching by the super high precise large led cabinet

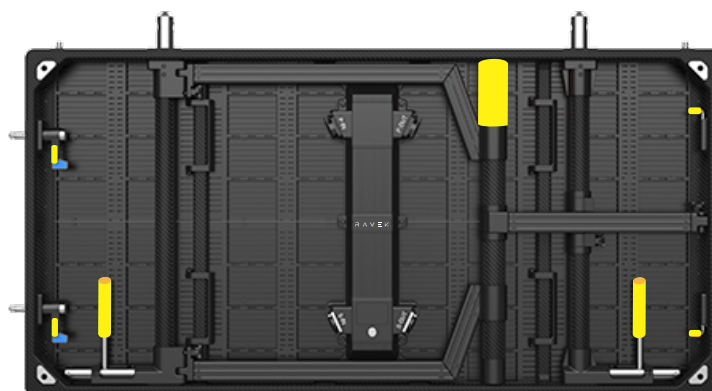

Modularized design

Integrated detachable control box + pure carbon fiber frame + fully magnetic modules

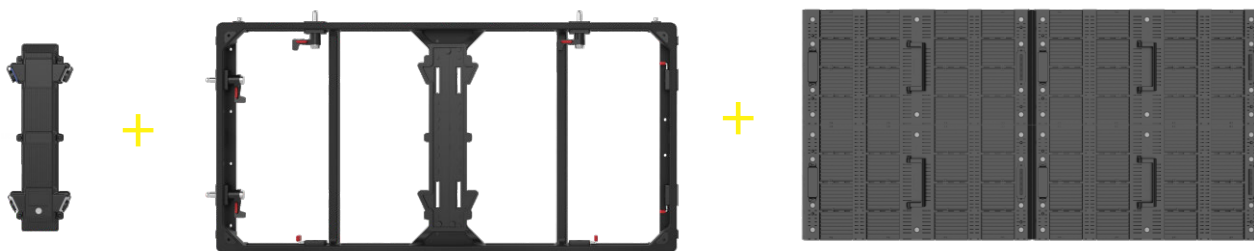

Fully magnetic & super large format led module

Super large format design on led module 500*250mm, no any screws and is fully magnetic by 10pcs magnets per module to ensure its fastness, safety and efficiency, also easy for front & rear maintenance

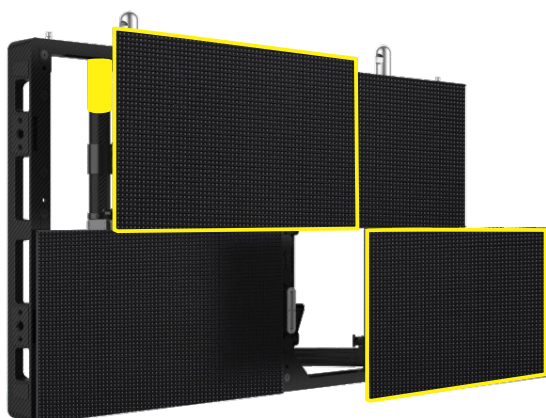

Vertical/horizontal led modules can be exchanged freely

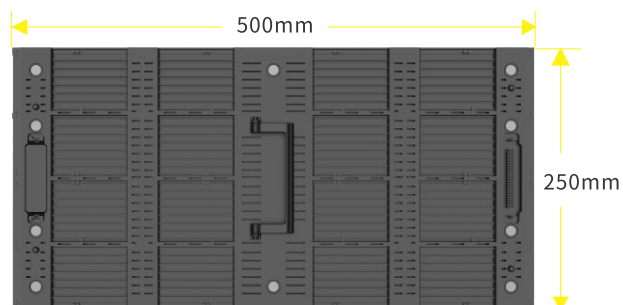

Fully magnetic large led module without any screws
10pcs magnets per module

Light, thin & durable

- Easy to install by one person, and with lower installation/transportation cost.

Ultra light carbon fiber which is anti-corrosion + creative hollow design

- It is a 30% lighter than aluminium, while strength is 20 times than steel and tensile strength ability up to 3500 Mpa



T: 63mm

Ultra light carbon fiber led frame with creative hollow design



W: 7.8kg

Clip-type module

Clip-type module handle is creative and operation ability is strong

It is a handle, but also the safety lock to avoid led module from dropping what assures the safety, and makes the maintenance efficiently and convenient

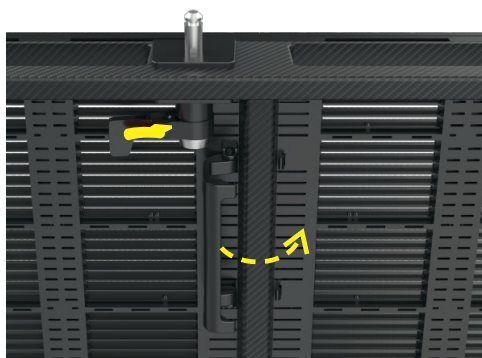

Free replacing in different led modules

Universal led frame is compatible for both hollow & non-hollow led modules, the transparency up to 49%

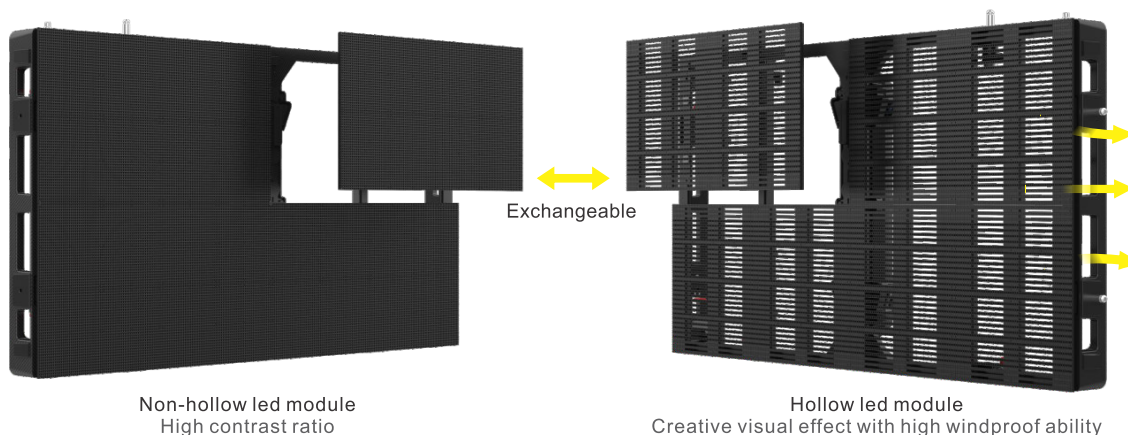

Non-hollow led module
High contrast ratio

Hollow led module
Creative visual effect with high windproof ability

Excellent image processing by high grayscale

Applied the 14bit high grayscale to process the images deeply so that picture's hierarchy and color can be presented perfectly, also details can be showed well without any informations loss.

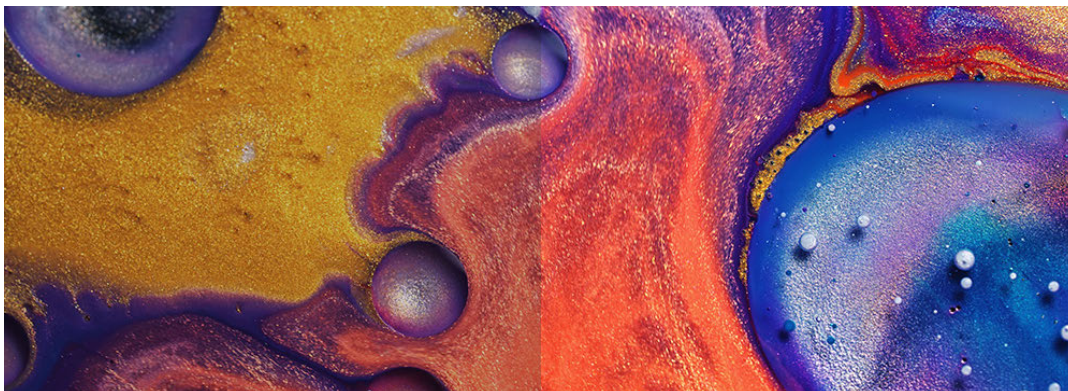

14-bit

Super high refresh rate

Applied the high-end drive IC for high refresh rate ($>3840\text{HZ}$) to capture the stable images without flicking and high quality of dynamic images to restore the images' reality accurately



$\geq 3840\text{HZ}$

IP rate

Ip65 protection rate which is waterproof, moisture-proff and dust-proof with wider applications

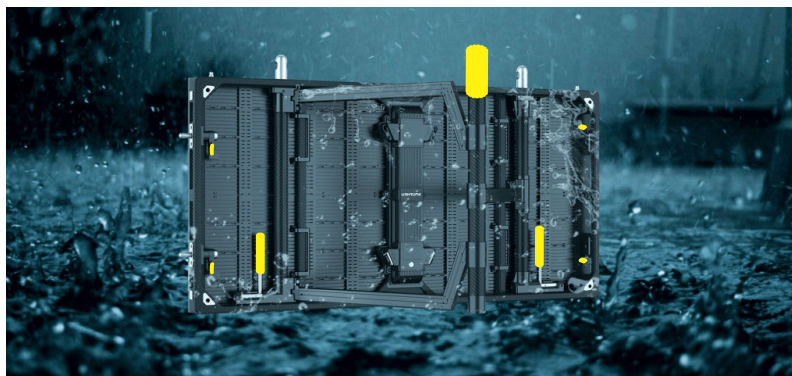

Fully covered by super wider viewing angles

Well-selected LED lamp with wide viewing angles + fully viewing angle mask without brim that make the led screen's viewing angles up to H140°V 140°, and no visual blind spot

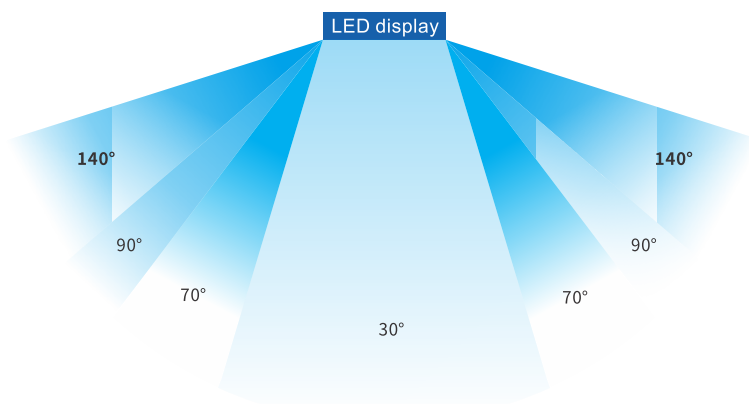

Seamless stitching with high precision

Super high precision carbon fiber led cabinet by owned CNC workshop that the deviation can be control in +/-0.02mm, and to come true the real seamless stitching instantly

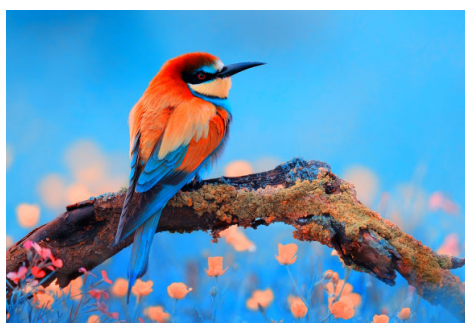
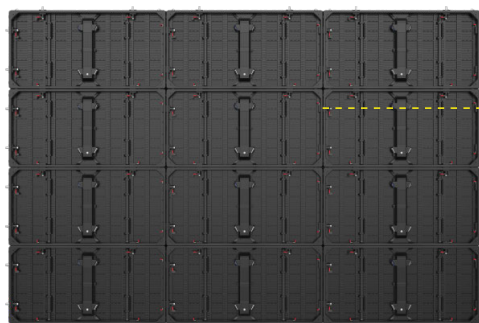

Upgraded structure - wind brace

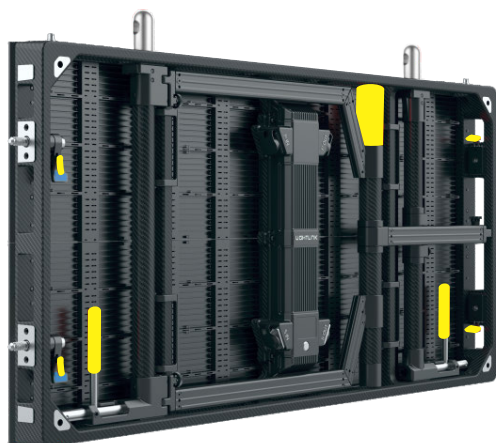

Folded wind brace design for better screen transportation

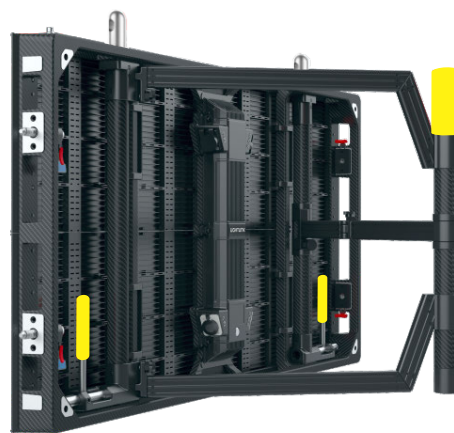

Use with wind brace makes it more stable and safe

Angle and thickness of wind brace while open

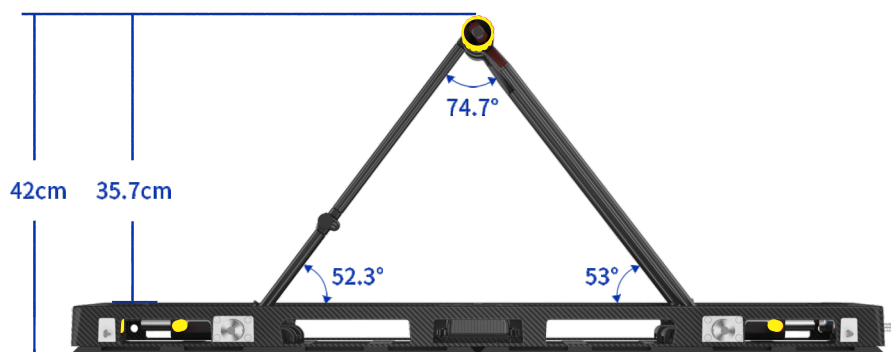

Installation

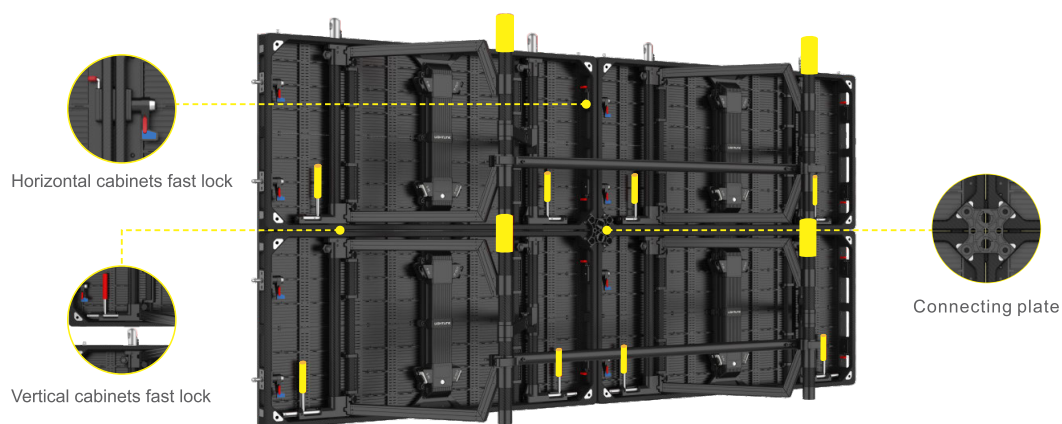

Wind rating test

Wind resistance up to 25m/s



Stacking



Hanging

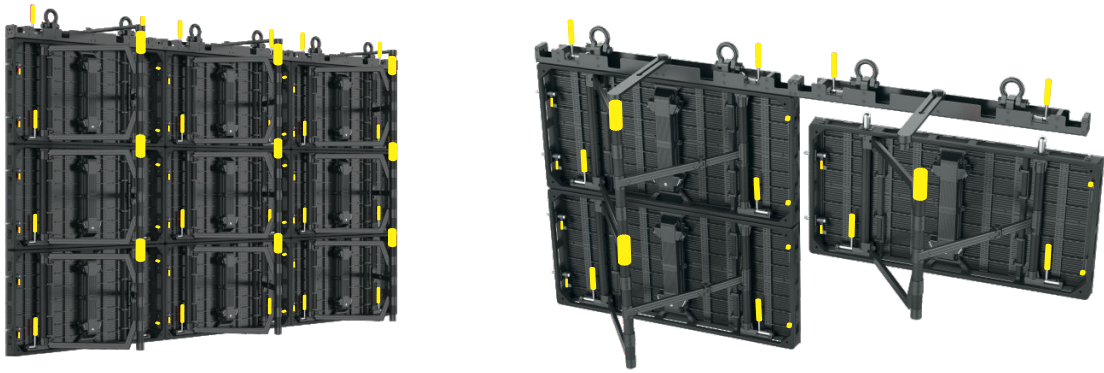

Touring cart

Touring carts size speically designed to fit for US standar truck

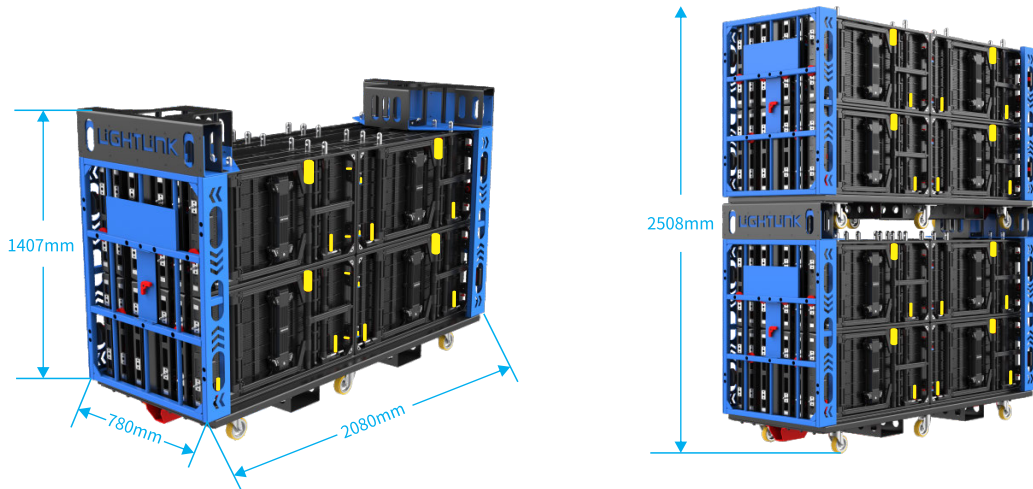

Applications



Specifications

Specifications	Indoor	Outdoor	Outdoor mesh	
Pixel pitch(mm)	H: 3.9 V: 3.9	H: 5.9 V: 5.9	H: 3.9 V: 7.8	H: 5.9 V: 5.9
LED type	SMD 2121	SMD 1921	SMD 1921	SMD 1921
Scan method	1/16s	1/16s	1/16s	1/7s
Module resolution(Pixels)	128*64	84*42	128*32	84*42
Module size(mm)	500*250	500*250	500*250	500*250
Pixel Density(Pixels/m ²)	65,526	28,224	32,768	28,224
Brightness(cd/m ²)	800	5000	3000	4000-4500
Viewing Angle(H/V)	H:140 V:140	H:140 V:140	H:140 V:140	H:140 V:140
Cabinet Size(mm)	1000(W)*500(H)*63(D)	1000(W)*500(H)*63(D)	1000(W)*500(H)*63(D)	1000(W)*500(H)*63(D)
Cabinet Material	Carbon fiber	Carbon fiber	Carbon fiber	Carbon fiber
Cabinet weight(kg)	≈7.8	≈8.3	≈7.8	≈7.8
Refresh rate(Hz)	≥3840	≥3840	≥3840	≥3840
Input voltage(V)	AC110,220,110-240	AC110,220,110-240	AC110,220,110-240	AC110,220,110-240
Input power frequency(Hz)	50/60	50/60	50/60	50/60
Max Input Power(W/m ²)	≈600	≈600	≈400	≈600
Average Input Power(W/m ²)	≈300	≈300	≈200	≈300
Lifespan(H)	≥50,000	≥50,000	≥50,000	≥50,000
Transparency	/	/	49%	49%
Maintenance	Front & rear	Front & rear	Front & rear	Front & rear
IP Rate	IP20	IP65	IP65	IP65

Configurations



Power supply

Code: 103010236
 Notes: Output 4.5V/80A
 Input 100-240VAC



Hanging beam

Code: 112120415
 Dimension: 1000*60*60mm
 Weight: 8.1kg
 Notes: 1 cabinets/beam, Max height ≤40m



System

Brand: Nova/Colorlight



Ground stacking

Code: 112180118
 Dimension: 1000*765*200mm
 Notes: Max height ≤40m



Cabinet plug

Brand: Seetronic/Cnlinko



Connecting clamp

Code: 112010662
 Dimension: 1058*50*50mm
 Weight: 1.2kg
 Notes: available for climbing

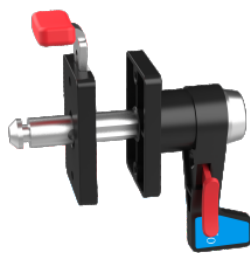

Fast lock

Code: 112090466
 Dimension: 81.7*72*30mm

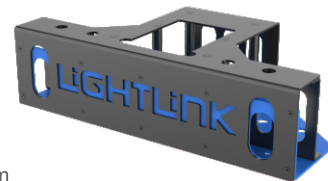

Top support base

Code: 112220319
 Dimension: 410*780*205mm
 Weight: 12.5kg
 Notes: carts spare ,for stacking 2 layers



wind brace

Code: 117010003
 Dimension: 463.9*810*403.5mm
 Weight: 3.6kg
 Notes: wind resistance 25m/sec

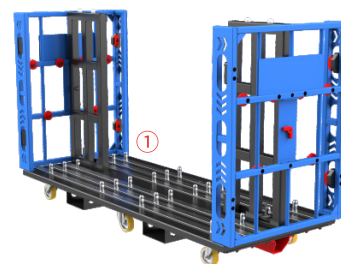

Touring cart

Dimension: 1223*2080*780mm
 Weight: 194kg
 Notes: can do 2 layer and hold weight up to 1200KG
 Basement
 Code: 112330316
 Dimension: 1900*780*244mm



w w w . m e g a v i e w . u s